

SYSTEM D-GROOVING

Einstecken mit ein- oder zweischneidigen Schneideinsätzen

grooving with one- or two-cutting edges inserts

Typ DZ24.MV

Schneideinsatz lang, zweischneidig, Spanformer MV (Vollradius)

insert long, two-cutting edges, chipbreaker MV (full radius)

Stechbreite b
2.0 / 3.0 / 4.0 / 5.0 / 6.0 mm

width of groove b
2.0 / 3.0 / 4.0 / 5.0 / 6.0 mm

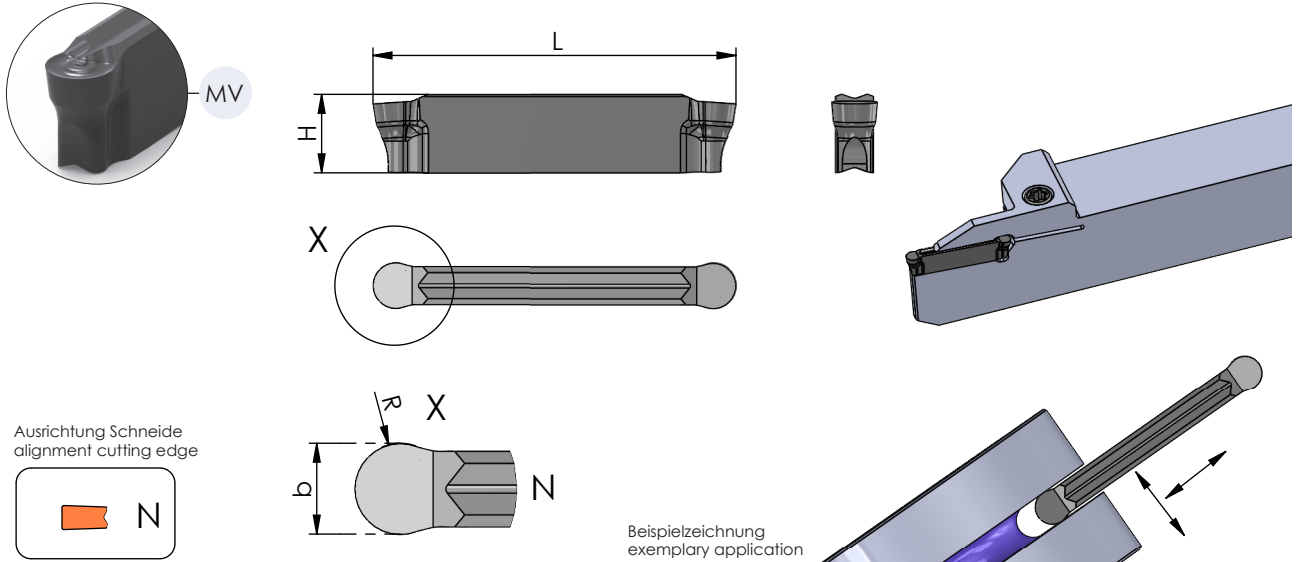

Ausrichtung Schneide alignment cutting edge



Beispielzeichnung exemplary application

Neutral (N): wie gezeichnet

Neutral (N): as shown

Abmessungen in mm

dimensions in mm

	Bestellnummer part number	b	R	L	H	α	Ausrichtung Schneide alignment cutting edge					Klemmhalter Typ toolholder type	Klinge Typ blade type
								P04C	VC10	VP12	K06P		
neu	DZ24.N20VR.MV	2.0	1.0	24	5.15	0°	N	●	●	●			
neu	DZ24.N30VR.MV	3.0	1.5	24	5.15	0°	N	●	●	●			
neu	DZ24.N40VR.MV	4.0	2.0	24	5.15	0°	N	●	●	●	DHR. ... DHL. ...	DKR.D24 DKL.D24 DKN.D24	
neu	DZ24.N50VR.MV	5.0	2.5	24	5.15	0°	N	●	●	●			
neu	DZ24.N60VR.MV	6.0	3.0	24	5.15	0°	N	●	●	●			



Bestellbeispiel:
für Sorte P04C:
DZ24.N20VR.MV/P04C

order-example:
grade P04C:
DZ24.N20VR.MV/P04C